

NR887D Current Mode Control, Synchronous Rectifier Step-down Switching Mode

Features

- DIP 8 pin package
- Input voltage range (V_{IN}): $V_O + 3$ to 18 V
- Synchronous rectifier mode
- High efficiency: 90%
- Introduction of current mode control method
- A ceramic capacitor can be used for output
- Built-in phase correction component
- Output current: 2 A
- Reference voltage and accuracy of $0.8\text{ V} \pm 2\%$
- Oscillation frequency: 500 kHz
- Output ON/OFF available
- Undervoltage lockout
- Soft start function

Applications

- Power supply for LCDTV and PDP
- Power supply for DVD, BD, and STB
- On-board local power supply
- Power supply for switches

Electrical Characteristics

($T_a=25^\circ\text{C}$, $V_{IN}=12\text{V}$, $V_O=3.3\text{V}$, and $I_O=1.0\text{A}$, unless otherwise specified)

Parameter	Symbol	Ratings			Unit	Conditions
		min.	typ.	max.		
Reference Voltage	V_{REF}	0.784	0.800	0.816	V	
Temperature Coefficient of Reference Voltage	$\Delta V_{REF}/\Delta T$		± 0.05		mV/C	$T_a=-40^\circ\text{C}$ to $+85^\circ\text{C}$
Efficiency	η		90		%	
Oscillation Frequency	f_o	400	500	600	kHz	
Line Regulation	V_{LINE}		50		mV	$V_{IN}=6.3\text{V}$ to 18V
Load Regulation	V_{Load}		50		mV	$I_O=0.1$ to 2.0A
Overcurrent Protection Starting Current	I_S	3.1		6.0	A	
Quiescent Circuit Current 1	I_{IN}		6		mA	$V_{EN}=10\Omega$ pull up to V_{IN}
Quiescent Circuit Current 2	$I_{IN(off)}$			10	μA	$I_O=0\text{A}$, $V_{EN}=0\text{V}$
SS Pin	Outflow Current at Low Voltage	6	10	14	μA	$V_{SS}=0\text{V}$
	Open Voltage		3.0		V	
EN Pin	Inflow Current		50	100	μA	$V_{EN}=10\text{V}$
	On Threshold Voltage	0.7	1.4	2.1	V	
Maximum ON Duty	$DMAX$		90		%	
Minimum ON Time	$DMIN$		150		nsec	
Thermal Protection Start Temperature	TSD	151	165		$^\circ\text{C}$	
Thermal Protection Return Hysteresis	TSD_hys		20		$^\circ\text{C}$	

*: Pin 8 is the SS pin. Soft start at power on can be performed with a capacitor connected to this pin. The SS pin is pulled up to the power supply in the IC, so applying the external voltage is prohibited.

Absolute Maximum Ratings

Parameter	Symbol	Ratings	Unit	Conditions
Input Voltage	V_{IN}	20	V	
Power Dissipation	P_D	1.50	W	When mounted on a 70×60 mm glass-epoxy board (with a 1310 mm^2 copper area)
Junction Temperature	T_J	-40 to $+150$	$^\circ\text{C}$	
Storage Temperature	T_{stg}	-40 to $+150$	$^\circ\text{C}$	
Thermal Resistance (Junction to Lead (4 pins))	θ_{j-c}	25	$^\circ\text{C}/\text{W}$	
Thermal Resistance (Junction to Ambient Air)	θ_{j-a}	67	$^\circ\text{C}/\text{W}$	When mounted on a 70×60 mm glass-epoxy board (with a 1310 mm^2 copper area)

Recommended Operating Conditions

Parameter	Symbol	Ratings	Unit
Input Voltage Range	V_{IN}	4.5 or $V_O + 3^*$ to 18	V
Output Current Range	I_O	0 to 2.0	A
Output Voltage Range	V_O	0.8 to 14	V
Operating Temperature Range	T_{op}	-40 to $+85$	$^\circ\text{C}$

*: The minimum value of the input voltage range is 4.5 V or $V_O + 3$ V, whichever is higher.

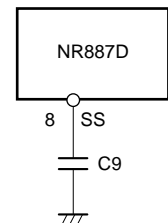

External Dimensions (DIP8)

(Unit : mm)

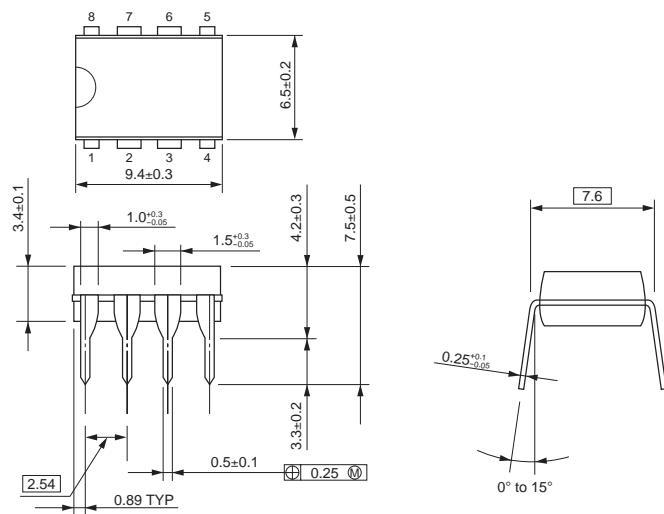

Pin Assignment

- ① BS
- ② VIN
- ③ SW
- ④ GND
- ⑤ FB
- ⑥ NC
- ⑦ EN
- ⑧ SS

Plastic Mold Package Type
 Flammability: UL 94V-0
 Product Mass: Approx. 0.49g

Block Diagram

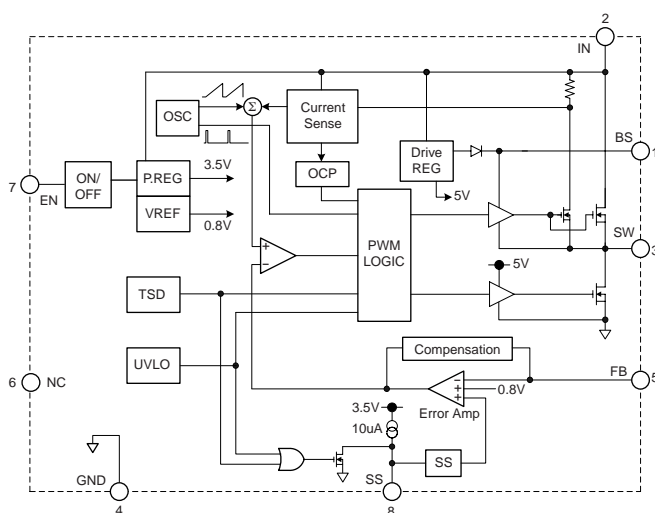

Typical Connection Diagram

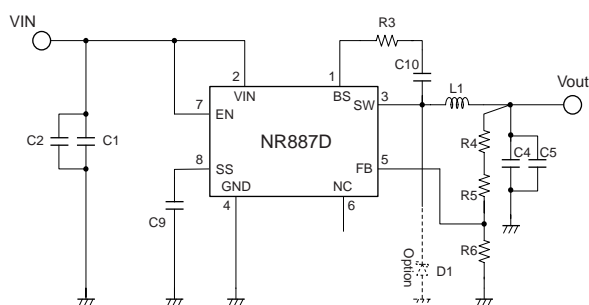

C1, C2: 10 μ F/25V
 C4, C5: 22 μ F/16V
 C9: 0.1 μ F
 C10: 0.1 μ F
 L1: 10 μ H
 R3: 20 Ω to 47 Ω
 R4+R5: 5k Ω (Vo=3.3V)
 R6: 1.6k Ω